

# 350G LC/380G LC

35–38 metric ton



JOHN DEERE





# Put more work within reach.

Whether you're loading trucks, digging trenches, demolishing structures, or placing pipe, you'll get more done with our G-Series Excavators. Their rugged EPA Interim Tier 4 (IT4)/EU Stage IIIIB PowerTech™ diesel engines meet rigid emission regulations, enabling you to work, everywhere there's work, even in nonattainment areas. Customer-inspired refinements include a more comfortable, spacious cab. And an enhanced LCD monitor with simplified navigation that lets an operator easily dial-in a wealth of machine information and functionality. Exceptional power, smoothness, and ease of operation — the 350G LC and 380G LC deliver all you've come to expect in a John Deere excavator. And then some.

	<b>350G LC</b>	<b>380G LC</b>
<b>Net rated power</b>	202 kW (271 hp)	202 kW (271 hp)
<b>Operating weight</b>	34 726 kg (76,557 lb.)	37 200 kg (82,012 lb.)
<b>Lifting capacity</b>	12 851 kg (28,331 lb.)	13 254 kg (29,220 lb.)
<b>Maximum digging depth</b>	8.18 m (26 ft. 10 in.)	8.18 m (26 ft. 10 in.)
<b>Arm digging force</b>	152.6–159.0 kN (34,314–35,745 lb.)	152.6–159.0 kN (34,314–35,745 lb.)
<b>Bucket digging force</b>	225.2–246.0 kN (50,628–55,303 lb.)	225.2–246.0 kN (50,628–55,303 lb.)

With John Deere WorkSight™, JDLink™ monitoring provides real-time machine utilization and health data, plus location information. FleetCare proactively suggests maintenance to correct problems early before they turn into costly downtime. And Service ADVISOR™ Remote enables your dealer to read diagnostic codes, record performance data, and even update software without a trip to the jobsite. It's the most comprehensive, easy-to-use suite of technology available for increasing uptime and productivity while lowering operating costs. And it's only available from John Deere.





The IT4/Stage IIIB technology utilized in our PowerTech diesel engines is simple, fuel efficient, fully integrated, and fully supported.

With unsurpassed visibility, a large entryway, generous legroom, and a supportive high-back seat, the G-Series' spacious cab delivers day-long convenience and comfort.

Highly efficient hydraulically driven fan runs only as needed, reducing noise, fuel consumption, and operating costs. Reversing option automatically back-blows cooler cores to keep them clean.

Extended engine and hydraulic oil-service intervals increase uptime and reduce daily operating costs.



Need extra stability or lift capacity? Opt for the 380G LC. Its standard heavy-duty boom, 3.2-m (10 ft. 6 in.) arm, and undercarriage provide the stamina and strength to handle demanding tasks in pipeline, demolition, and scrap-handling tasks.

Choose from a variety of track widths, arm lengths, buckets, high-flow auxiliary hydraulic packages, and numerous other options.



## Work harder. And smarter.

Who says you have to choose between working harder and working smarter? With our enhanced engine/hydraulic management system commanding more hydraulic muscle, these excavators do both — putting that extra ability to work with typically smooth operation and finesse. Add to these other John Deere advantages such as three power modes, power boost, and JDLink, and this excavator provides everything you need to give productivity an extra push. Combining brawn and brains, our G-Series Excavators are a wise choice.





Powerwise III perfectly balances engine performance and hydraulic flow for predictable operation. Three productivity modes allow you to choose the digging style that fits the job. **High-productivity** delivers more power and faster hydraulic response to move more material. **Power** delivers a balance of power, speed, and fuel economy for normal operation. **Economy** limits top speed and helps save fuel.

1. Low-effort joysticks, unmatched metering, and smooth multifunction operation deliver the control and finesse you need for utilities work.

2. Generous flow, arm force, and swing torque help speed cycles. So you can do your best to stay on schedule or ahead of the weather.

3. When the task calls for a little extra, simply press the power-boost button on the right-hand control and muscle through.

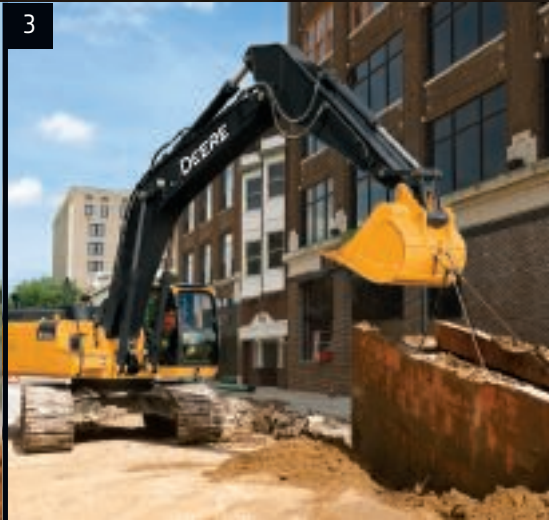



The image shows the interior of a John Deere tractor cab. The operator's seat is a light-colored, high-back fabric seat. In front of the seat is a control panel with a large, grey, rotary-style joystick. To the left of the joystick is a cup holder containing a silver travel mug. The dashboard area is yellow and features several warning labels with text like 'DANGER', 'WARNING', and 'IMPORTANT'. The overall design is functional and ergonomic.

# Operating ease takes a turn for the better.

Now it's easier than ever for your operators to "dial things up." The G-Series' refined monitor employs a rotary control that makes it quick and easy to tap into an abundance of performance and convenience functions and features. Operators will also appreciate the comfortable fabric-covered high-back seat and increased legroom in the spacious, well-appointed cab. As always, unsurpassed all-round visibility, low-effort joysticks, a highly efficient HVAC system, and numerous other amenities provide everything needed to do your best work.



With large self-cleaning steps and wide entryways, getting to and from “the office” has never been easier.

Spacious cab is comfortable and noticeably quiet. Silicone-filled mounts effectively isolate operators from noise and vibration.

We've got your back with a sculpted mechanical-suspension high-back seat. Seat has 267 mm (10½ in.) of travel, sliding together or independent of the joystick console. So it won't cramp an operator's style. For even more support and comfort, opt for the air-suspension heated seat.

Ergonomically correct short-throw pilot levers provide smooth, predictable fingertip control with less movement or effort. Push buttons in the right lever allow fingertip control of auxiliary hydraulic flow for operating attachments.

No shortage of storage in here. There's a place for a cooler, cup holders, and even a hot/cold box that keeps beverages at just the right temperature.

Optional cab and right-side boom lights provide extra illumination to extend your workday beyond daylight hours.

1. Multi-language LCD monitor and rotary dial provide intuitive access to a wealth of information and functions. Just turn and tap to select work mode, access operating info, check maintenance intervals, source diagnostic codes, adjust cab temperature, and tune the radio. Plus much more.
2. Wide expanse of front and side glass, narrow front cab posts, large overhead glass, and numerous mirrors provide virtually unobstructed all-around visibility. If you need to see more, choose the optional camera that displays the action behind on the monitor.
3. Automatic, high-velocity bi-level climate-control system with automotive-style adjustable louvers helps keep the glass clear and the cab comfortable.



1



2



3



# Nothing runs like a Deere, because nothing is built like one.

When you've got places to go, people to see, and schedules to keep, you need dependable workers like these. Built to deliver unsurpassed uptime, these go-getters employ many of the same job-proven digging structures and hydraulic, electrical, and undercarriage components as their highly regarded predecessors. You'll also continue to profit from durability-enhancing "extras" such as tungsten-carbide-coated wear surfaces, welded-boom bulkheads, wet-sleeve engine liners, and extended service intervals. When you know how they're built, you'll run a Deere.

Graphite-iron wet-sleeve cylinder liners, mono-steel pistons, and large-diameter connecting rods ensure long-term engine durability.

Tungsten-carbide coating creates an extremely wear-resistant surface to protect the all-important bucket-to-arm joint.

Oil-impregnated bushings enhance durability and extend grease intervals to 500 hours for the arm-and-boom joint and 100 hours for the bucket joint.

1. Thick-plate single-sheet mainframe, box-section track frames, and industry-exclusive double-seal swing bearing deliver rock-solid durability.

2. With large idlers, rollers, and strutted links, the sealed and lubricated undercarriage delivers long and reliable performance.

3. Highly efficient, heavy-duty cooling system keeps things cool, even in tough environments or high altitudes.

4. Reinforced D-channel side frames provide maximum cab and component protection.

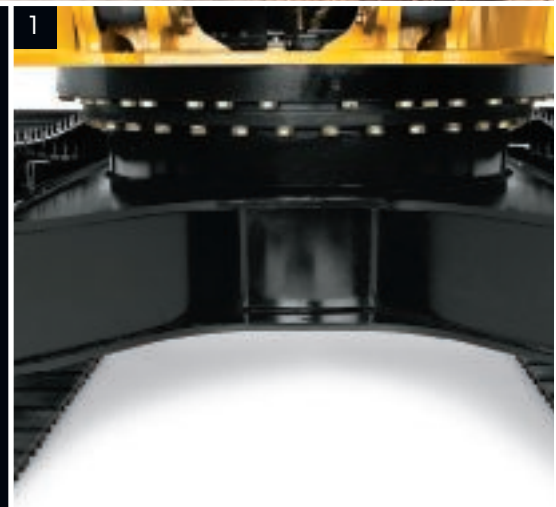





Our EPA IT4/EU Stage IIIB technology is simple, fuel efficient, fully integrated, and fully supported. It employs field-proven cooled exhaust gas recirculation (EGR) for reducing NO<sub>x</sub>, and a diesel particulate filter (DPF) and diesel oxidation catalyst (DOC) to reduce particulate matter.

A John Deere exclusive, three welded bulkheads within the boom resist torsional stress for unsurpassed durability.

Reinforced resin thrust plates, grooved bushings, and thermal-coated bucket joints increase arm and boom lube intervals to 500 hours.

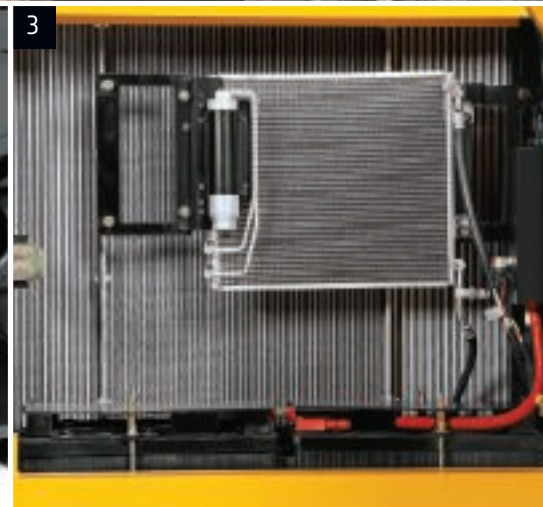

2

3

4



# Seeking simplified maintenance? You'll be a big fan of the G-Series.

Swing open the side panels and you'll discover many of the numerous ways this excavator can minimize maintenance, increase uptime, and reduce daily operating costs. Take the heavy-duty cooling system, for example. Its hydraulically driven fan runs only as fast or often as needed, reducing fuel consumption and wear-causing debris flow through the cooler cores. As always, grouped service points make quick work of the daily routine. Easy-to-check sight gauges and fluid reservoirs. Quick-change remote-mounted filters. Convenient fluid-sample ports and advanced self-diagnostics — with time- and money-saving advantages such as these, there's more to like.

Perforations in the hood and side shields serve as a "first filter," helping prevent trash entry. Anything that passes through will also clear the cooler cores.

Optional reversing fan back-blows cooler cores to reduce debris buildup. It's a welcome addition that helps increase uptime.

Auto-idle automatically reduces engine speed when hydraulics aren't in use. Auto-shutdown further preserves precious fuel.

EPA IT4/EU Stage IIIB diesel particulate filter is easily removed through the top of the engine compartment. Minimum service interval is 4,500 hours, and can be done by your John Deere dealer.



## Engine Oil Filter

### Previous Maintenance

2012/11/05 0.0h

Remains 498.8h

Maintenance Interval 500.0h







Large fuel tanks and 500- and 5,000-hour engine and hydraulic oil-service intervals decrease downtime for routine maintenance.

Fluid-level sight gauges are conveniently located and can be checked at a glance.

Convenient color-coded lubrication and maintenance chart helps ensure that nothing gets overlooked.

1. Easy-to-navigate LCD monitor issues scheduled maintenance alerts. Should a problem arise, it provides diagnostic information to help decrease downtime.
2. Fluid-sample and remote diagnostic ports help speed preventative maintenance and troubleshooting.
3. Vertical spin-on engine oil and fuel filters are conveniently located in the right rear compartment for easy ground-level servicing.
4. Ground-level fresh-air cab filter is quickly serviced from outside the cab. Where it's more likely to get done.
5. Centralized lube banks place difficult-to-lube zerks within easy reach. They make greasing less messy and time consuming, too.
6. Cooler cores' 10-fin-per-inch spacing lets trash easily pass to resist plugging. Hinged, swing-out coolers provide added core access.



4



5



6



# 350G LC



Engine	350G LC		
	Base engine for use in U.S., U.S. Territories, and Canada	Optional engine for use outside the U.S. and U.S. Territories	Optional engine for use outside the U.S., U.S. Territories, and Canada
Manufacturer and Model	John Deere PowerTech™ PSX 9.0 L	John Deere PowerTech™ Plus 9.0 L	John Deere PowerTech™ 9.0 L
Non-Road Emissions Standard	EPA Interim Tier 4/EU Stage IIIB	EPA Tier 3/EU Stage IIIA	EPA Tier 2/EU Stage II
Net Rated Power (ISO 9249)	202 kW (271 hp) at 1,900 rpm	202 kW (271 hp) at 1,900 rpm	202 kW (271 hp) at 1,900 rpm
Cylinders	6	6	6
Displacement	9.0 L (549 cu. in.)	9.0 L (549 cu. in.)	9.0 L (549 cu. in.)
Off-Level Capacity	70% (35 deg.)	70% (35 deg.)	70% (35 deg.)
Aspiration	Turbocharged, air-to-air charge-air cooler	Turbocharged, air-to-air charge-air cooler	Turbocharged, air-to-air charge-air cooler
<b>Cooling</b>			
Cool-on-demand hydraulic-driven, suction-type fan with remote-mounted drive			
<b>Powertrain</b>			
2-speed propel with automatic shift			
<b>Maximum Travel Speed</b>			
Low	3.2 km/h (2.0 mph)		
High	5.0 km/h (3.1 mph)		
Drawbar Pull	29 200 kg (64,375 lb.)		
<b>Hydraulics</b>			
Open center, load sensing			
<b>Main Pumps</b>	2 variable-displacement pumps		
Maximum Rated Flow	288 L/m (76.1 gpm) x 2		
<b>Pilot Pump</b>	One gear		
Maximum Rated Flow	34 L/m (8.9 gpm)		
Pressure Setting	3900 kPa (566 psi)		
<b>System Operating Pressure</b>			
Circuits			
Implement	34 300 kPa (4,975 psi)		
Travel	35 500 kPa (5,149 psi)		
Swing	33 300 kPa (4,830 psi)		
Power Boost	38 000 kPa (5,511 psi)		
<b>Controls</b>	Pilot levers, short stroke, low-effort hydraulic pilot controls with shutoff lever		
<b>Cylinders</b>			
	<i>Bore</i>	<i>Rod Diameter</i>	<i>Stroke</i>
<b>Boom (2)</b>	145 mm (5.7 in.)	100 mm (3.9 in.)	1520 mm (59.8 in.)
<b>Arm (1)</b>	170 mm (6.7 in.)	115 mm (4.5 in.)	1740 mm (68.5 in.)
<b>Bucket (1)</b>	140 mm (5.5 in.)	95 mm (3.7 in.)	1250 mm (49.2 in.)
<b>Electrical</b>			
Number of Batteries (12 volt)	2		
Battery Capacity	1,400 CCA		
Alternator Rating	100 amp		
Work Lights	2 halogen (one mounted on boom, one on frame)		
<b>Undercarriage</b>			
<b>Rollers (each side)</b>			
Carrier	2		
Track	8		
Shoes, Triple Semi-Grousers (each side)	48		
<b>Track</b>			
Adjustment	Hydraulic		
Guides	3 per side		
Chain	Sealed and lubricated		





<b>Ground Pressure</b>	<b>350G LC</b>
800-mm (32 in.) Triple Semi-Grouser Shoes	52.8 kPa (7.66 psi)

<b>Swing Mechanism</b>	
Speed	10.7 rpm
Torque	120 000 Nm (88,507 lb.-ft.)

<b>Serviceability</b>	
<b>Refill Capacities</b>	

Fuel Tank	628 L (166 gal.)
Cooling System	39.7 L (10.5 gal.)
Engine Oil with Filter	27 L (7.2 gal.)
Hydraulic Tank	193 L (51 gal.)
Hydraulic System	290 L (77 gal.)
Swing Drive	11.8 L (12.5 qt.)
Gearbox	
Propel (each)	8.5 L (9.0 qt.)
Pump Drive	1.1 L (1.2 qt.)

<b>Operating Weights</b>	
With full fuel tank; 79-kg (175 lb.) operator; 1.76-m <sup>3</sup> (2.3 cu. yd.), 1370-mm (54 in.), 1160-kg (2,557 lb.) bucket; 4.0-m (13 ft. 1 in.) arm; 6928-kg (15,274 lb.) counterweight; and 800-mm (32 in.) triple semi-grouser shoes	
Operating Weight	34 726 kg (76,557 lb.)

<b>Component Weights</b>	
Undercarriage with 800-mm (32 in.) Triple Semi-Grouser Shoes	12 710 kg (28,020 lb.)
One-Piece Boom (with arm cylinder)	3031 kg (6,682 lb.)
Arm with Bucket Cylinder and Linkage	
2.66 m (8 ft. 9 in.)	1649 kg (3,635 lb.)
3.2 m (10 ft. 6 in.)	1758 kg (3,876 lb.)
4.0 m (13 ft. 1 in.)	1898 kg (4,184 lb.)
Boom-Lift Cylinders (2), Total Weight	624 kg (1,376 lb.)
1.76-m <sup>3</sup> (2.3 cu. yd.), 1370-mm (54 in.) Heavy-Duty Bucket	1160 kg (2,557 lb.)
Counterweight, Standard	6928 kg (15,274 lb.)

<b>Operating Dimensions</b>			
<b>Arm Length</b>	<i>2.66 m (8 ft. 9 in.)</i>	<i>3.2 m (10 ft. 6 in.)</i>	<i>4.0 m (13 ft. 1 in.)</i>

<b>Arm Digging Force</b>			
SAE	204.2 kN (45,914 lb.)	177.6 kN (39,930 lb.)	152.6 kN (34,314 lb.)
ISO	222.0 kN (49,908 lb.)	185.0 kN (41,590 lb.)	159.0 kN (35,745 lb.)
<b>Bucket Digging Force</b>			
SAE	225.2 kN (50,628 lb.)	225.2 kN (50,628 lb.)	225.2 kN (50,628 lb.)
ISO	246.0 kN (55,303 lb.)	246.0 kN (55,303 lb.)	246.0 kN (55,303 lb.)
<b>Lifting Capacity Over Front at Ground Level 6.1-m (20 ft.) Reach (with power boost)</b>			
<b>A</b> Maximum Reach	10.57 m (34 ft. 8 in.)	11.10 m (36 ft. 5 in.)	11.86 m (38 ft. 11 in.)
<b>A'</b> Maximum Reach at Ground Level	10.36 m (34 ft. 0 in.)	10.89 m (35 ft. 9 in.)	11.67 m (38 ft. 3 in.)
<b>B</b> Maximum Digging Depth	6.84 m (22 ft. 5 in.)	7.38 m (24 ft. 3 in.)	8.18 m (26 ft. 10 in.)
<b>B'</b> Maximum Digging Depth at 2.44-m (8 ft. 0 in.) Flat Bottom	6.64 m (21 ft. 9 in.)	7.21 m (23 ft. 8 in.)	8.04 m (26 ft. 5 in.)
<b>C</b> Maximum Cutting Height	9.99 m (32 ft. 9 in.)	10.36 m (34 ft. 0 in.)	10.75 m (35 ft. 3 in.)
<b>D</b> Maximum Dumping Height	6.94 m (22 ft. 9 in.)	7.24 m (23 ft. 9 in.)	7.63 m (25 ft. 0 in.)
<b>E</b> Minimum Swing Radius	4.61 m (15 ft. 1 in.)	4.46 m (14 ft. 8 in.)	4.47 m (14 ft. 8 in.)
<b>F</b> Maximum Vertical Wall	5.51 m (18 ft. 1 in.)	6.42 m (21 ft. 1 in.)	7.27 m (23 ft. 10 in.)
<b>G</b> Tail-Swing Radius	3.60 m (11 ft. 10 in.)	3.60 m (11 ft. 10 in.)	3.60 m (11 ft. 10 in.)

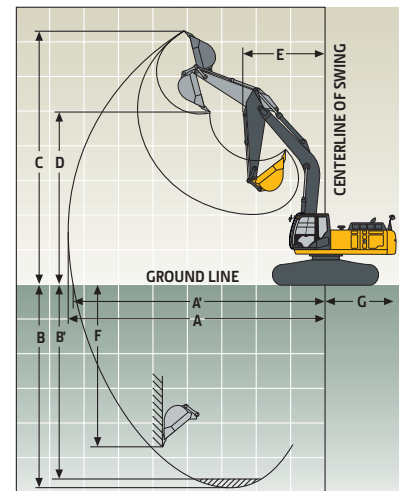



**Machine Dimensions 350G LC**

<b>A</b> Overall Length	2.66 m (8 ft. 9 in.)	11.33 m (37 ft. 2 in.)
	3.2 m (10 ft. 6 in.)	11.20 m (36 ft. 9 in.)
	4.0 m (13 ft. 1 in.)	11.29 m (37 ft. 1 in.)
<b>B</b> Overall Height	2.66 m (8 ft. 9 in.)	3.47 m (11 ft. 5 in.)
	3.2 m (10 ft. 6 in.)	3.27 m (10 ft. 9 in.)
	4.0 m (13 ft. 1 in.)	3.60 m (11 ft. 10 in.)
<b>C</b> Rear-End Length/Swing Radius	3.60 m (11 ft. 10 in.)	
<b>D</b> Distance Between Idler/Sprocket Centerline	4.05 m (13 ft. 3 in.)	
<b>E</b> Undercarriage Length	4.94 m (16 ft. 2 in.)	
<b>F</b> Counterweight Clearance	1.18 m (3 ft. 10 in.)	
<b>G</b> Upperstructure Width	2.99 m (9 ft. 10 in.)	
<b>H</b> Cab Height	3.14 m (10 ft. 4 in.)	
<b>I</b> Track Width with Shoes	600 mm (24 in.) / 700 mm (28 in.) / 800 mm (32 in.)	
<b>J</b> Gauge Width	2.59 m (8 ft. 6 in.)	
<b>K</b> Ground Clearance	0.50 m (20 in.)	
<b>L</b> Overall Width with Shoes	600 mm (24 in.)	3.19 m (10 ft. 6 in.)
	700 mm (28 in.)	3.29 m (10 ft. 10 in.)
	800 mm (32 in.)	3.39 m (11 ft. 2 in.)

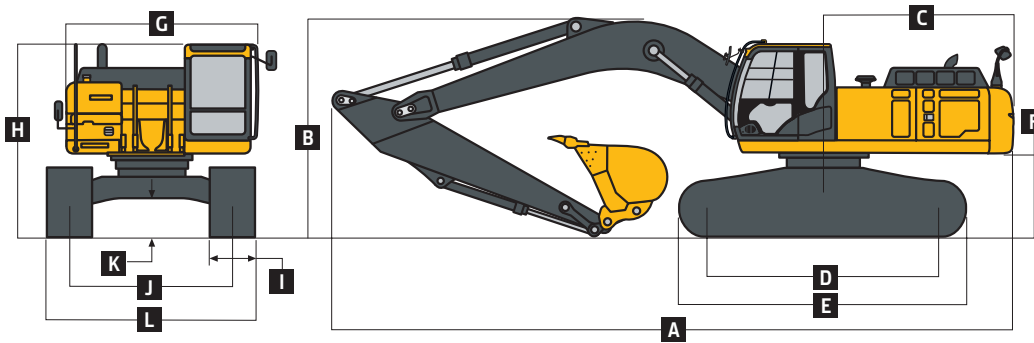

**Lift Capacities**

**Boldface type** indicates hydraulically limited capacity; **lightface type** indicates stability-limited capacities, in kg (lb.). All lift capacities are based on ISO 10567 (with power boost). Machine equipped with 1170-kg (2,580 lb.) bucket and 800-mm (32 in.) shoes; standard gauge; and situated on firm, uniform supporting surface. Total load includes weight of cables, hook, etc. Figures do not exceed 87 percent of hydraulic capacities or 75 percent of weight needed to tip machine.

Load Point Height	1.5 m (5 ft.)		3.0 m (10 ft.)		4.5 m (15 ft.)		6.0 m (20 ft.)		7.5 m (25 ft.)		9.0 m (30 ft.)		
Horizontal Distance from Centerline of Rotation	Over Front	Over Side	Over Front	Over Side	Over Front	Over Side	Over Front	Over Side	Over Front	Over Side	Over Front	Over Side	
<i>With 2.66-m (8 ft. 9 in.) arm</i>													
6.0 m (20 ft.)							<b>9496</b>	9213	<b>8705</b>	6162			
							<b>(20,636)</b>	(19,803)	<b>(19,093)</b>	(13,179)			
4.5 m (15 ft.)			<b>14 206</b>	14 021	<b>10 894</b>	8801	<b>9279</b>	6021					
			<b>(30,447)</b>	(30,255)	<b>(23,562)</b>	(18,960)	<b>(20,190)</b>	(12,922)					
3.0 m (10 ft.)			<b>17 742</b>	12 827	<b>12 506</b>	8285	<b>9573</b>	5798					
			<b>(38,067)</b>	(27,693)	<b>(27,011)</b>	(17,857)	<b>(20,571)</b>	(12,462)					
1.5 m (5 ft.)					<b>13 399</b>	7868	<b>9319</b>	5570					
					<b>(36,850)</b>	(26,125)	<b>(28,794)</b>	(16,949)					
Ground Line					<b>18 814</b>	11 932	<b>13 127</b>	7634	<b>9155</b>	5423			
					<b>(42,867)</b>	(25,647)	<b>(28,197)</b>	(16,432)	<b>(19,685)</b>	(11,666)			
-1.5 m (-5 ft.)			<b>12 495</b>	<b>12 495</b>	<b>18 754</b>	11 959	<b>13 059</b>	7575	<b>9117</b>	5389			
			<b>(28,545)</b>	<b>(28,545)</b>	<b>(40,705)</b>	(25,693)	<b>(28,045)</b>	(16,301)	<b>(19,617)</b>	(11,605)			
-3.0 m (-10 ft.)			<b>21 868</b>	<b>21 868</b>	<b>16 665</b>	12 147	<b>12 606</b>	7679					
			<b>(47,544)</b>	<b>(47,544)</b>	<b>(36,066)</b>	(26,109)	<b>(27,142)</b>	(16,540)					
-4.5 m (-15 ft.)			<b>16 500</b>	<b>16 500</b>	<b>12 776</b>	12 551							
			<b>(35,354)</b>	<b>(35,354)</b>	<b>(27,209)</b>	(27,027)							
<i>With 3.2-m (10 ft. 6 in.) arm</i>													
6.0 m (20 ft.)								<b>8008</b>	6249				
								<b>(17,528)</b>	(13,381)				
4.5 m (15 ft.)							<b>10 108</b>	8940	<b>8700</b>	6077			
							<b>(21,858)</b>	(19,242)	<b>(18,923)</b>	(13,042)			
3.0 m (10 ft.)			<b>16 457</b>	13 179	<b>11 834</b>	8402	<b>9604</b>	5832	<b>7003</b>	4180			
			<b>(35,331)</b>	(28,428)	<b>(25,561)</b>	(18,102)	<b>(20,664)</b>	(12,529)	<b>(15,009)</b>	(8,936)			
1.5 m (5 ft.)			<b>19 033</b>	12 300	<b>13 321</b>	7933	<b>9338</b>	5579	<b>6882</b>	4069			
			<b>(41,053)</b>	(26,492)	<b>(28,796)</b>	(17,084)	<b>(20,070)</b>	(11,995)	<b>(14,768)</b>	(8,714)			
Ground Line			<b>19 818</b>	11 930	<b>13 140</b>	7635	<b>9132</b>	5395	<b>6794</b>	3988			
			<b>(42,912)</b>	(25,649)	<b>(28,219)</b>	(16,430)	<b>(19,628)</b>	(11,598)	<b>(14,592)</b>	(8,553)			
-1.5 m (-5 ft.)			<b>11 956</b>	<b>11 956</b>	<b>19 291</b>	11 864	<b>13 002</b>	7516	<b>9042</b>	5314			
			<b>(27,138)</b>	<b>(27,138)</b>	<b>(41,824)</b>	(25,490)	<b>(27,916)</b>	(16,168)	<b>(19,442)</b>	(11,431)			
-3.0 m (-10 ft.)	<b>14 280</b>	<b>14 280</b>	<b>19 673</b>	<b>19 673</b>	<b>17 649</b>	11 988	<b>13 051</b>	7558	<b>9105</b>	5371			
	<b>(32,048)</b>	<b>(32,048)</b>	<b>(44,674)</b>	<b>(44,674)</b>	<b>(38,194)</b>	(25,762)	<b>(28,032)</b>	(16,269)	<b>(19,608)</b>	(11,580)			
-4.5 m (-15 ft.)			<b>19 521</b>	<b>19 521</b>	<b>14 491</b>	12 307	<b>10 645</b>	7794					
			<b>(41,956)</b>	<b>(41,956)</b>	<b>(31,054)</b>	(26,481)	<b>(22,511)</b>	(16,823)					



## Lift Capacities (continued) 350G LC

**Boldface type** indicates hydraulically limited capacity; lightface type indicates stability-limited capacities, in kg (lb.). All lift capacities are based on ISO 10567 (with power boost). Machine equipped with 1170-kg (2,580 lb.) bucket and 800-mm (32 in.) shoes; standard gauge; and situated on firm, uniform supporting surface. Total load includes weight of cables, hook, etc. Figures do not exceed 87 percent of hydraulic capacities or 75 percent of weight needed to tip machine.

Load Point Height	1.5 m (5 ft.)		3.0 m (10 ft.)		4.5 m (15 ft.)		6.0 m (20 ft.)		7.5 m (25 ft.)		9.0 m (30 ft.)			
Horizontal Distance from Centerline of Rotation	Over Front	Over Side	Over Front	Over Side	Over Front	Over Side	Over Front	Over Side	Over Front	Over Side	Over Front	Over Side		
With 4.0-m (13 ft. 1 in.) arm														
7.5 m (25 ft.)											(14,716)	(13,856)		
6.0 m (20 ft.)											<b>7015</b>	6409	<b>5727</b>	4442
											<b>(15,348)</b>	(13,734)	<b>(11,021)</b>	(9,453)
4.5 m (15 ft.)											<b>7813</b>	6203	<b>7212</b>	4370
											<b>(16,997)</b>	(13,312)	<b>(15,462)</b>	(9,335)
3.0 m (10 ft.)											<b>14 409</b>	13 717	<b>10 708</b>	8612
											<b>(30,952)</b>	(29,563)	<b>(23,138)</b>	(18,543)
1.5 m (5 ft.)											<b>17 673</b>	12 624	<b>12 469</b>	8065
											<b>(38,094)</b>	(27,185)	<b>(26,955)</b>	(17,362)
Ground Line											<b>6735</b>	<b>6735</b>	<b>19 386</b>	12 004
											<b>(15,416)</b>	<b>(15,416)</b>	<b>(41,927)</b>	(25,812)
-1.5 m (-5 ft.)	<b>6807</b>	<b>6807</b>	<b>10 880</b>	<b>10 880</b>	<b>19 638</b>	11 769	12 949	7458	8974	5244	6692	3887		
	<b>(15,227)</b>	<b>(15,227)</b>	<b>(24,662)</b>	<b>(24,662)</b>	<b>(42,536)</b>	(25,286)	(27,797)	(16,037)	(19,285)	(11,269)	(14,381)	(8,342)		
-3.0 m (-10 ft.)	<b>11 398</b>	<b>11 398</b>	<b>16 291</b>	<b>16 291</b>	<b>18 694</b>	11 779	12 899	7414	8945	5218				
	<b>(25,572)</b>	<b>(25,572)</b>	<b>(36,941)</b>	<b>(36,941)</b>	<b>(40,455)</b>	(25,307)	(27,693)	(15,947)	(19,236)	(11,226)				
-4.5 m (-15 ft.)	<b>16 873</b>	<b>16 873</b>	<b>23 293</b>	<b>23 293</b>	<b>16 436</b>	11 987	<b>12 165</b>	7536	<b>8817</b>	5356				
	<b>(38,021)</b>	<b>(38,021)</b>	<b>(50,183)</b>	<b>(50,183)</b>	<b>(35,373)</b>	(25,775)	<b>(26,067)</b>	(16,233)	<b>(18,456)</b>	(11,576)				
-6.0 m (-20 ft.)			<b>16 669</b>	<b>16 669</b>	<b>12 038</b>	<b>12 038</b>	<b>8137</b>	7927						
			<b>(35,135)</b>	<b>(35,135)</b>	<b>(25,239)</b>	<b>(25,239)</b>								

## Buckets

A full line of buckets is offered to meet a wide variety of applications. Digging forces are with power boost. Buckets are equipped with John Deere Fanggs™ teeth or ESCO teeth standard. Replaceable cutting edges and a variety of teeth are available through John Deere Parts. Optional side cutters add 150 mm (6 in.) to bucket widths. Capacities are SAE heaped ratings.

Type Bucket	Bucket Width		Bucket Capacity		Bucket Weight		Bucket Dig Force		Arm Dig Force		Arm Dig Force		Arm Dig Force		Bucket Tip Radius	Number of Teeth	
	mm	in.	m <sup>3</sup>	cu. yd.	kg	lb.	kN	lb.	kN	lb.	kN	lb.	kN	lb.			mm
Heavy Duty Plate Lip	915	36	1.13	1.5	971	2,140	225.2	496	204.2	450	177.6	392	152.6	337	1600	63.0	4
	1065	42	1.34	1.7	1003	2,212	225.2	496	204.2	450	177.6	392	152.6	337	1600	63.0	5
	1220	48	1.55	2.0	1055	2,326	225.2	496	204.2	450	177.6	392	152.6	337	1600	63.0	6
	1372	54	1.76	2.3	1161	2,559	225.2	496	204.2	450	177.6	392	152.6	337	1600	63.0	6
Heavy Duty High Capacity	760	30	0.96	1.3	1142	2,518	204.2	450	196.6	433	171.7	379	148.3	327	1765	69.5	4
	915	36	1.19	1.6	1263	2,783	204.2	450	196.6	433	171.7	379	148.3	327	1765	69.5	4
	1065	42	1.41	1.8	1416	3,123	204.2	450	196.6	433	171.7	379	148.3	327	1765	69.5	5
	1220	48	1.64	2.1	1506	3,321	204.2	450	196.6	433	171.7	379	148.3	327	1765	69.5	6
	1372	54	1.87	2.4	1617	3,565	204.2	450	196.6	433	171.7	379	148.3	327	1765	69.5	6

## Bucket Selection Guide\*

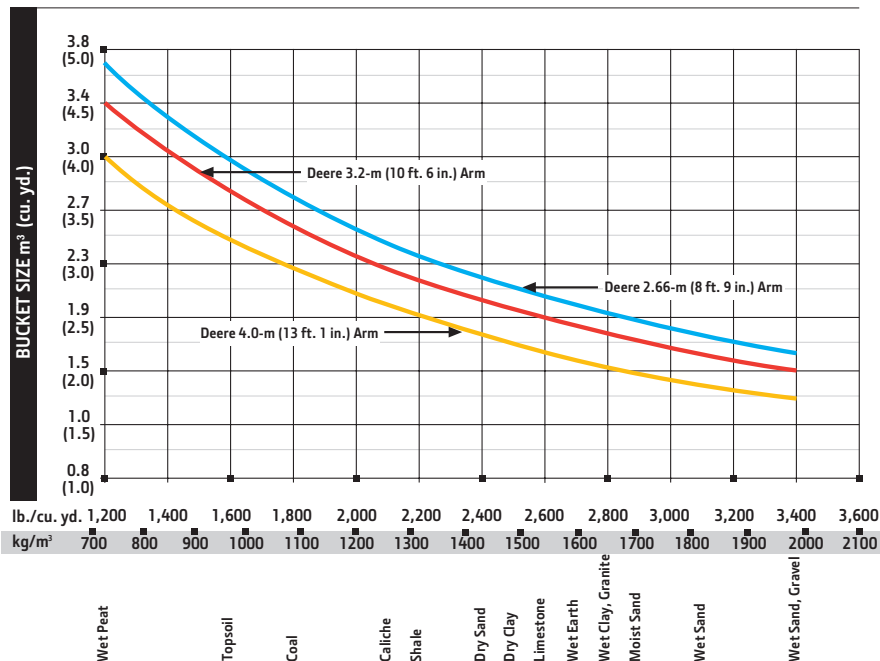

\*Contact your John Deere dealer for optimum bucket and attachment selections. These recommendations are for general conditions and average use. Does not include optional equipment such as thumbs or couplers. Larger buckets may be possible when using light materials, for flat and level operations, less compacted materials, and volume loading applications such as mass-excavation applications in ideal conditions. Smaller buckets are recommended for adverse conditions such as off-level applications, rocks, and uneven surfaces. Bucket capacity indicated is SAE heaped.



# 380G LC

Engine	380G LC		
	Base engine for use in U.S., U.S. Territories, and Canada	Optional engine for use outside the U.S. and U.S. Territories	
Manufacturer and Model	John Deere PowerTech™ PSX 9.0 L	John Deere PowerTech™ Plus 9.0 L	
Non-Road Emissions Standard	EPA Interim Tier 4/EU Stage IIIB	EPA Tier 3/EU Stage IIIA	
Net Rated Power (ISO 9249)	202 kW (271 hp) at 1,900 rpm	202 kW (271 hp) at 1,900 rpm	
Cylinders	6	6	
Displacement	9.0 L (549 cu. in.)	9.0 L (549 cu. in.)	
Off-Level Capacity	70% (35 deg.)	70% (35 deg.)	
Aspiration	Turbocharged, air-to-air charge-air cooler	Turbocharged, air-to-air charge-air cooler	
Cooling	Cool-on-demand hydraulic-driven, suction-type fan with remote-mounted drive		
Powertrain	2-speed propel with automatic shift		
Maximum Travel Speed			
Low	3.2 km/h (2.0 mph)		
High	5.0 km/h (3.1 mph)		
Drawbar Pull	29 200 kg (64,375 lb.)		
Hydraulics	Open center, load sensing		
Main Pumps	2 variable-displacement pumps		
Maximum Rated Flow	288 L/m (76.1 gpm) x 2		
Pilot Pump	One gear		
Maximum Rated Flow	34 L/m (8.9 gpm)		
Pressure Setting	3900 kPa (566 psi)		
System Operating Pressure			
Circuits			
Implement	34 300 kPa (4,975 psi)		
Travel	35 500 kPa (5,149 psi)		
Swing	33 300 kPa (4,830 psi)		
Power Boost	38 000 kPa (5,511 psi)		
Controls	Pilot levers, short stroke, low-effort hydraulic pilot controls with shutoff lever		
Cylinders			
	<i>Bore</i>	<i>Rod Diameter</i>	<i>Stroke</i>
Boom (2)	145 mm (5.7 in.)	100 mm (3.9 in.)	1520 mm (59.8 in.)
Arm (1)	170 mm (6.7 in.)	115 mm (4.5 in.)	1740 mm (68.5 in.)
Bucket (1)	140 mm (5.5 in.)	95 mm (3.7 in.)	1250 mm (49.2 in.)
Electrical			
Number of Batteries (12 volt)	2		
Battery Capacity	1,400 CCA		
Alternator Rating	100 amp		
Work Lights	2 halogen (one mounted on boom, one on frame)		
Undercarriage			
Rollers (each side)			
Carrier	2		
Track	8		
Shoes, Triple Semi-Grousers (each side)	48		
Track			
Adjustment	Hydraulic		
Guides	3 per side		
Chain	Sealed and lubricated		





**Ground Pressure 380G LC**

800-mm (32 in.) Heavy-Duty Triple Semi-Grouser Shoes 56.5 kPa (8.20 psi)

**Swing Mechanism**

Speed 10.7 rpm  
Torque 120 000 Nm (88,507 lb.-ft.)

**Serviceability**

**Refill Capacities**

Fuel Tank	628 L (166 gal.)
Cooling System	39.7 L (10.5 gal.)
Engine Oil with Filter	27 L (7.2 gal.)
Hydraulic Tank	193 L (51 gal.)
Hydraulic System	290 L (77 gal.)
Swing Drive	11.8 L (12.5 qt.)
Gearbox	
Propel (each)	8.5 L (9.0 qt.)
Pump Drive	1.1 L (1.2 qt.)

**Operating Weights**

With full fuel tank; 79-kg (175 lb.) operator; 1.76-m<sup>3</sup> (2.3 cu. yd.), 1370-mm (54 in.), 1160-kg (2,557 lb.) bucket; 4.0-m (13 ft. 1 in.) arm; 7629-kg (16,819 lb.) counterweight; and 800-mm (32 in.) Heavy-Duty triple semi-grouser shoes

Operating Weight 37 200 kg (82,012 lb.)

**Component Weights**

Undercarriage, Heavy-Duty, with 800-mm (32 in.) Heavy-Duty Triple Semi-Grouser Shoes	13 550 kg (29,872 lb.)
Heavy-Duty One-Piece Boom (with arm cylinder)	3541 kg (7,806 lb.)
Arm with Bucket Cylinder and Linkage	
3.2 m (10 ft. 6 in.) Heavy Duty	1957 kg (4,315 lb.)
4.0 m (13 ft. 1 in.)	1898 kg (4,184 lb.)
Boom-Lift Cylinders (2), Total Weight	624 kg (1,376 lb.)
1.76-m <sup>3</sup> (2.3 cu. yd.), 1370-mm (54 in.) Heavy-Duty Bucket	1160 kg (2,557 lb.)
Counterweight, Standard	7629 kg (16,819 lb.)

**Operating Dimensions**

Arm Length	3.2 m (10 ft. 6 in.) Heavy Duty	4.0 m (13 ft. 1 in.)
Arm Digging Force		
SAE	177.6 kN (39,930 lb.)	152.6 kN (34,314 lb.)
ISO	185.0 kN (41,590 lb.)	159.0 kN (35,745 lb.)
Bucket Digging Force		
SAE	225.2 kN (50,628 lb.)	225.2 kN (50,628 lb.)
ISO	246.0 kN (55,303 lb.)	246.0 kN (55,303 lb.)
Lifting Capacity Over Front at Ground Level 6.1-m (20 ft.) Reach (with power boost)		
<b>A</b> Maximum Reach	11.10 m (36 ft. 5 in.)	11.86 m (38 ft. 11 in.)
<b>A'</b> Maximum Reach at Ground Level	10.89 m (35 ft. 9 in.)	11.67 m (38 ft. 3 in.)
<b>B</b> Maximum Digging Depth	7.38 m (24 ft. 3 in.)	8.18 m (26 ft. 10 in.)
<b>B'</b> Maximum Digging Depth at 2.44-m (8 ft. 0 in.) Flat Bottom	7.21 m (23 ft. 8 in.)	8.04 m (26 ft. 5 in.)
<b>C</b> Maximum Cutting Height	10.36 m (34 ft. 0 in.)	10.75 m (35 ft. 3 in.)
<b>D</b> Maximum Dumping Height	7.24 m (23 ft. 9 in.)	7.63 m (25 ft. 0 in.)
<b>E</b> Minimum Swing Radius	4.46 m (14 ft. 8 in.)	4.47 m (14 ft. 8 in.)
<b>F</b> Maximum Vertical Wall	6.42 m (21 ft. 1 in.)	7.27 m (23 ft. 10 in.)
<b>G</b> Tail-Swing Radius	3.60 m (11 ft. 10 in.)	3.60 m (11 ft. 10 in.)

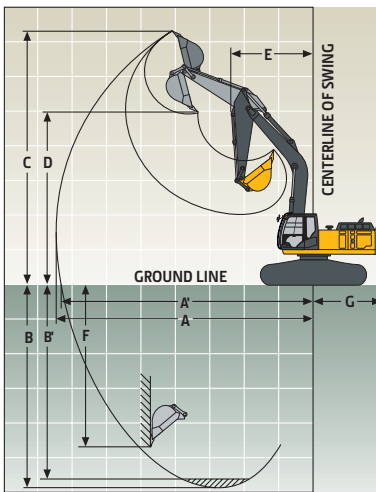



**Machine Dimensions 380G LC**

<b>A</b> Overall Length		
3.2 m (10 ft. 6 in.) Heavy Duty	11.20 m (36 ft. 9 in.)	
4.0 m (13 ft. 1 in.)	11.29 m (37 ft. 1 in.)	
<b>B</b> Overall Height		
3.2 m (10 ft. 6 in.) Heavy Duty	3.27 m (10 ft. 9 in.)	
4.0 m (13 ft. 1 in.)	3.60 m (11 ft. 10 in.)	
<b>C</b> Rear-End Length/Swing Radius	3.60 m (11 ft. 10 in.)	
<b>D</b> Distance Between Idler/Sprocket Centerline	4.05 m (13 ft. 3 in.)	
<b>E</b> Undercarriage Length	4.94 m (16 ft. 2 in.)	
<b>F</b> Counterweight Clearance	1.18 m (3 ft. 10 in.)	
<b>G</b> Upperstructure Width	2.99 m (9 ft. 10 in.)	
<b>H</b> Cab Height	3.17 m (10 ft. 5 in.)	
<b>I</b> Track Width	700 mm (28 in.) Heavy Duty / 800 mm (32 in.) Heavy Duty	
<b>J</b> Gauge Width	2.59 m (8 ft. 6 in.)	
<b>K</b> Ground Clearance	0.50 m (20 in.)	
<b>L</b> Overall Width with Shoes		
700 mm (28 in.) Heavy Duty	3.29 m (10 ft. 10 in.)	
800 mm (32 in.) Heavy Duty	3.39 m (11 ft. 2 in.)	

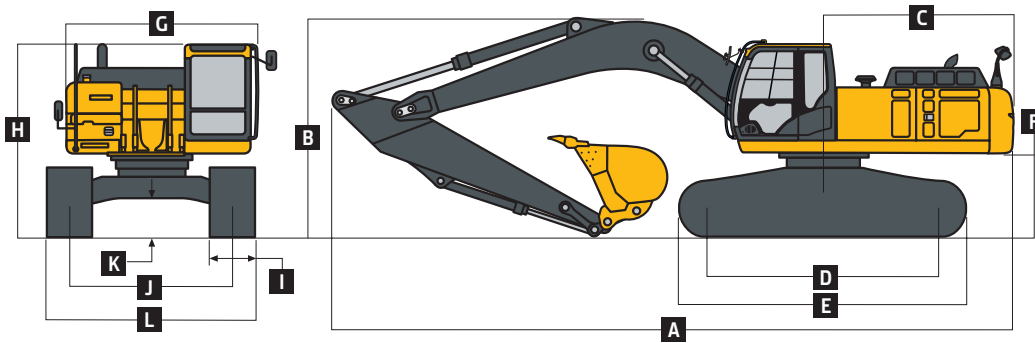

**Lift Capacities**

**Boldface type** indicates hydraulically limited capacity; **lightface type** indicates stability-limited capacities, in kg (lb.). All lift capacities are based on ISO 10567 (with power boost). Machine equipped with 1270-kg (2,800 lb.) bucket and 800-mm (32 in.) Heavy-Duty shoes; standard gauge; and situated on firm, uniform supporting surface. Total load includes weight of cables, hook, etc. Figures do not exceed 87 percent of hydraulic capacities or 75 percent of weight needed to tip machine.

Load Point Height	1.5 m (5 ft.)		3.0 m (10 ft.)		4.5 m (15 ft.)		6.0 m (20 ft.)		7.5 m (25 ft.)		9.0 m (30 ft.)	
Horizontal Distance from Centerline of Rotation	Over Front	Over Side	Over Front	Over Side	Over Front	Over Side	Over Front	Over Side	Over Front	Over Side	Over Front	Over Side
<i>With 3.2-m (10 ft. 6 in.) Heavy-Duty arm</i>												
6.0 m (20 ft.)									<b>7806</b>	6710		
									<b>(17,082)</b>	(14,371)		
4.5 m (15 ft.)							<b>9878</b>	9578	<b>8475</b>	6515	<b>6368</b>	4579
							<b>(21,357)</b>	(20,618)	<b>(18,430)</b>	(13,985)		
3.0 m (10 ft.)					<b>16 096</b>	14 063	<b>11 549</b>	8981	<b>9351</b>	6241	7495	4479
					<b>(34,555)</b>	(30,342)	<b>(24,944)</b>	(19,352)	<b>(20,278)</b>	(13,410)	(16,066)	(9,578)
1.5 m (5 ft.)					<b>18 594</b>	13 091	<b>12 991</b>	8462	9974	5961	7360	4356
					<b>(40,102)</b>	(28,200)	<b>(28,079)</b>	(18,225)	(21,440)	(12,817)	(15,795)	(9,329)
Ground Line					<b>19 348</b>	12 683	<b>13 792</b>	8133	9747	5757	7262	4266
					<b>(41,891)</b>	(27,271)	<b>(29,848)</b>	(17,503)	(20,953)	(12,380)	(15,602)	(9,152)
-1.5 m (-5 ft.)			<b>11 896</b>	<b>11 896</b>	<b>18 817</b>	12 614	<b>13 787</b>	8003	9650	5670		
			<b>(27,023)</b>	<b>(27,023)</b>	<b>(40,794)</b>	(27,102)	<b>(29,755)</b>	(17,218)	(20,751)	(12,198)		
-3.0 m (-10 ft.)	<b>14 227</b>	<b>14 227</b>	<b>19 619</b>	<b>19 619</b>	<b>17 190</b>	12 755	<b>12 828</b>	8053	<b>9604</b>	5735		
	<b>(31,928)</b>	<b>(31,928)</b>	<b>(44,624)</b>	<b>(44,624)</b>	<b>(37,195)</b>	(27,413)	<b>(27,670)</b>	(17,335)	<b>(20,489)</b>	(12,369)		
-4.5 m (-15 ft.)			<b>18 938</b>	<b>18 938</b>	<b>14 064</b>	13 113	<b>10 310</b>	8318				
			<b>(40,693)</b>	<b>(40,693)</b>	<b>(30,129)</b>	(28,219)	<b>(21,788)</b>	(17,958)				

## Lift Capacities (continued) 380G LC

**Boldface type** indicates hydraulically limited capacity; lightface type indicates stability-limited capacities, in kg (lb.). All lift capacities are based on ISO 10567 (with power boost). Machine equipped with 1270-kg (2,800 lb.) bucket and 800-mm (32 in.) Heavy-Duty shoes; standard gauge; and situated on firm, uniform supporting surface. Total load includes weight of cables, hook, etc. Figures do not exceed 87 percent of hydraulic capacities or 75 percent of weight needed to tip machine.

Load Point Height	1.5 m (5 ft.)		3.0 m (10 ft.)		4.5 m (15 ft.)		6.0 m (20 ft.)		7.5 m (25 ft.)		9.0 m (30 ft.)			
Horizontal Distance from Centerline of Rotation	Over Front	Over Side	Over Front	Over Side	Over Front	Over Side	Over Front	Over Side	Over Front	Over Side	Over Front	Over Side		
With 4.0-m (13 ft. 1 in.) arm														
7.5 m (25 ft.)									(14,562)	(14,562)				
6.0 m (20 ft.)									<b>6939</b>	<b>6939</b>	<b>5716</b>	4868		
4.5 m (15 ft.)									(15,179)	(14,954)	(11,000)	(10,368)		
3.0 m (10 ft.)									<b>7721</b>	6752	<b>7114</b>	4789		
1.5 m (5 ft.)									(16,795)	(14,497)	(15,557)	(10,238)		
Ground Line			6730	6730	19 133	12 967	14 260	10 586	9333	8725	6451	7629	4642	
			(15,403)	(15,403)	(41,379)	(27,888)	(30,632)	(22,873)	(20,101)	(18,928)	(13,862)	(16,451)	(9,938)	
-1.5 m (-5 ft.)	6799	6799	10 863	10 863	19 370	12 713	17 458	13 633	8747	9704	6133	7490	4478	
	(15,210)	(15,210)	(24,660)	(24,660)	(41,953)	(27,321)	(37,630)	(29,362)	(26,612)	(18,836)	(21,034)	(13,184)	(16,079)	(9,597)
-3.0 m (-10 ft.)	11 387	11 387	16 293	16 293	18 425	12 723	17 458	13 633	8747	9704	6133	7490	4478	
	(25,561)	(25,561)	(36,911)	(36,911)	(39,871)	(27,341)	(37,630)	(29,362)	(26,612)	(18,836)	(21,034)	(13,184)	(16,079)	(9,597)
-4.5 m (-15 ft.)	16 888	16 888	22 921	22 921	16 178	12 944	17 458	13 633	8747	9704	6133	7490	4478	
	(37,963)	(37,963)	(49,377)	(49,377)	(34,814)	(27,840)	(37,630)	(29,362)	(26,612)	(18,836)	(21,034)	(13,184)	(16,079)	(9,597)
-6.0 m (-20 ft.)			16 336	16 336	11 807	11 807	17 458	13 633	8747	9704	6133	7490	4478	
			(34,418)	(34,418)	(24,741)	(24,741)	(37,630)	(29,362)	(26,612)	(18,836)	(21,034)	(13,184)	(16,079)	(9,597)

## Buckets

A full line of buckets is offered to meet a wide variety of applications. Digging forces are with power boost. Buckets are equipped with John Deere Fanggs™ teeth or ESCO teeth standard. Replaceable cutting edges and a variety of teeth are available through John Deere Parts. Optional side cutters add 150 mm (6 in.) to bucket widths. Capacities are SAE heaped ratings.

Type Bucket	Bucket Width		Bucket Capacity		Bucket Weight		Bucket Dig Force		Arm Dig Force 3.2 m (10 ft. 6 in.) Heavy Duty		Arm Dig Force 4.0 m (13 ft. 1 in.)		Bucket Tip Radius		Number of Teeth
	mm	in.	m <sup>3</sup>	cu. yd.	kg	lb.	kN	lb.	kN	lb.	kN	lb.	mm	in.	
Heavy Duty Plate Lip	915	36	1.13	1.5	971	2,140	225.2	496	177.6	392	152.6	337	1600	63.0	4
	1065	42	1.34	1.7	1003	2,212	225.2	496	177.6	392	152.6	337	1600	63.0	5
	1220	48	1.55	2.0	1055	2,326	225.2	496	177.6	392	152.6	337	1600	63.0	6
	1372	54	1.76	2.3	1161	2,559	225.2	496	177.6	392	152.6	337	1600	63.0	6
Heavy Duty High Capacity	760	30	0.96	1.3	1142	2,518	204.2	450	171.7	379	148.3	327	1765	69.5	4
	915	36	1.19	1.6	1263	2,783	204.2	450	171.7	379	148.3	327	1765	69.5	4
	1065	42	1.41	1.8	1416	3,123	204.2	450	171.7	379	148.3	327	1765	69.5	5
	1220	48	1.64	2.1	1506	3,321	204.2	450	171.7	379	148.3	327	1765	69.5	6
	1372	54	1.87	2.4	1617	3,565	204.2	450	171.7	379	148.3	327	1765	69.5	6

## Bucket Selection Guide\*

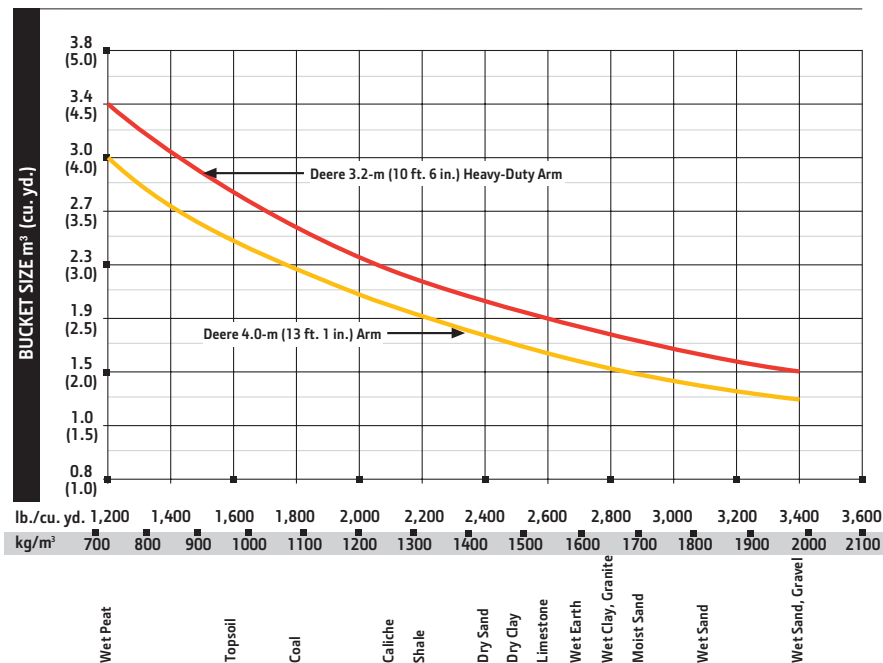

\*Contact your John Deere dealer for optimum bucket and attachment selections. These recommendations are for general conditions and average use. Does not include optional equipment such as thumbs or couplers. Larger buckets may be possible when using light materials, for flat and level operations, less compacted materials, and volume loading applications such as mass-excavation applications in ideal conditions. Smaller buckets are recommended for adverse conditions such as off-level applications, rocks, and uneven surfaces. Bucket capacity indicated is SAE heaped.



# Additional equipment

Key: ● Standard ▲ Optional or special

See your John Deere dealer for further information.

## 350G 380G Engine

- ● Auto-idle system
- ● Automatic belt-tension device
- ● Batteries (2 – 12 volt)
- ● Coolant recovery tank
- ● Dual-element dry-type air filter
- ● Electronic engine control
- ● Enclosed fan guard (conforms to SAE J1308)
- ● Engine coolant to –37 deg. C (–34 deg. F)
- ● Programmable auto shutdown
- ● Fuel filter with water separator
- ● Full-flow oil filter
- ● Turbocharger with charge air cooler
- ● Cool-on-demand hydraulic-driven fan
- ● 500-hour engine-oil-change interval
- ● 70% (35 deg.) off-level capability
- ● Engine-oil-sampling valve
- ▲ ▲ Chrome exhaust stack
- ▲ ▲ Electric ether starting aid
- ▲ ▲ Hydraulic fan reverser
- ▲ ▲ Engine coolant heater
- ▲ ▲ Severe-duty fuel filter

## Hydraulic System

- ● Reduced-drift valve for boom down, arm in
- ● Auxiliary hydraulic valve section
- ● Spring-applied, hydraulically released automatic swing brake
- ● Auxiliary hydraulic-flow adjustments through monitor
- ● Auto power lift
- ● 5,000-hour hydraulic-oil-change interval
- ● Hydraulic-oil-sampling valve
- ▲ ▲ Auxiliary hydraulic lines
- ▲ ▲ Auxiliary pilot and electric controls
- ▲ ▲ Hydraulic filter restriction indicator kit
- ▲ ▲ Load-lowering control / Anti-drift device
- ▲ ▲ Single-pedal propel control
- ▲ ▲ Control pattern change valve

## Undercarriage

- ● Planetary drive with axial piston motors
- ● Propel motor shields
- ● Spring-applied, hydraulically released automatic propel brake
- ● Track guides, front idler and 3 additional
- ● 2-speed propel with automatic shift
- ● Upper carrier rollers (2)
- ● Sealed and lubricated track chain
- ● Triple semi-grouser shoes, 600 mm (24 in.)
- ● Triple semi-grouser shoes, 700 mm (28 in.)

## 350G 380G Undercarriage (continued)

- ● Single-bar shoes, 700 mm (28 in.) Heavy Duty
- ● Triple semi-grouser shoes, 800 mm (32 in.)
- ● Triple semi-grouser shoes, 800 mm (32 in.) Heavy Duty
- ▲ ▲ Undercarriage frame opening guard

## Upperstructure

- ● Right-hand, left-hand, and counterweight mirrors
- ● Vandal locks with ignition key: Cab door / Service doors / Toolbox
- ● Debris screen in side panel
- ● Remote-mounted engine oil and fuel filters

## Front Attachments

- ● Centralized lubrication system
- ● Dirt seals on all bucket pins
- ● Less boom and arm
- ● Oil-impregnated bushings
- ● Reinforced resin thrust plates
- ● Tungsten carbide thermal coating on arm-to-bucket joint
- ▲ ▲ Arm, 2.66 m (8 ft. 9 in.)
- ▲ ▲ Arm, 3.2 m (10 ft. 6 in.)
- ▲ ▲ Arm, 3.2 m (10 ft. 6 in.) Heavy Duty
- ▲ ▲ Arm, 4.0 m (13 ft. 1 in.)
- ▲ ▲ Attachment quick-couplers
- ▲ ▲ Boom cylinder with plumbing to main-frame for less boom and arm
- ▲ ▲ Buckets: Heavy duty / Heavy-duty high capacity / Side cutters and teeth
- ▲ ▲ "D" channel guard
- ▲ ▲ Material clamps
- ▲ ▲ Super-long fronts

## Operator's Station

- ● Adjustable independent-control positions (levers-to-seat, seat-to-pedals)
- ● AM/FM radio
- ● Auto climate control/air conditioner/heater/pressurizer
- ● Built-in Operator's Manual storage compartment and manual
- ● Cell-phone power outlet, 12 volt, 60 watt, 5 amp
- ● Coat hook
- ● Deluxe suspension cloth seat with 100-mm (4 in.) adjustable armrests
- ● Floor mat
- ● Front windshield wiper with intermittent speeds
- ● Gauges (illuminated): Engine coolant / Fuel
- ● Horn, electric
- ● Hourmeter, electric

## 350G 380G Operator's Station (continued)

- ● Hydraulic shutdown lever, all controls
- ● Hydraulic warm-up control
- ● Interior light
- ● Large cup holder
- ● Machine Information Center (MIC)
- ● Mode selectors (illuminated): Power modes – 3 / Travel modes – 2 with automatic shift / Work mode – one
- ● Multifunction, color LCD monitor with: Diagnostic capability / Multiple-language capabilities / Maintenance tracking / Clock / System monitoring with alarm features: Auto-idle indicator, engine air cleaner restriction indicator light, engine check, engine coolant temperature indicator light with audible alarm, engine oil pressure indicator light with audible alarm, low-alternator-charge indicator light, low-fuel indicator light, fault code alert indicator, fuel-rate display, wiper-mode indicator, work-lights-on indicator, and work-mode indicator
- ● Motion alarm with cancel switch (conforms to SAE J994)
- ● Power-boost switch on right console lever
- ● Auxiliary hydraulic control switches in right console lever
- ● SAE 2-lever control pattern
- ● Seat belt, 51 mm (2 in.), retractable
- ● Tinted glass
- ● Transparent tinted overhead hatch
- ● Hot/cold beverage compartment
- ▲ ▲ Air-suspension heated seat
- ▲ ▲ 24- to 12-volt D.C. radio convertors, 10 amp
- ▲ ▲ Hydraulic oil filter restriction indicator light
- ▲ ▲ Protection screens for cab front, rear, and side
- ▲ ▲ Seat belt, 76 mm (3 in.), non-retractable
- ▲ ▲ Window vandal-protection covers

## Electrical

- ● 100-amp alternator
- ● Blade-type multi-fused circuits
- ● Positive-terminal battery covers
- ● JDLink™ wireless communication system (available in specific countries; see your dealer for details)
- ▲ ▲ Rearview camera
- ▲ ▲ Cab extension wiring harness

## Lights

- ● Work lights: Halogen / One mounted on boom / One mounted on frame
- ▲ ▲ 2 lights mounted on cab / One mounted on right side of boom

Net engine power is with standard equipment including air cleaner, exhaust system, alternator, and cooling fan, at test conditions specified per ISO 9249. No derating is required up to 3050-m (10,000 ft.) altitude. Specifications and design subject to change without notice. Wherever applicable, specifications are in accordance with SAE standards. Except where otherwise noted, these specifications are based on units with 1370-mm (54 in.) buckets, full fuel tanks, and 79-kg (175 lb.) operators; a 350G LC unit with 6928-kg (15,274 lb.) counterweight and 800-mm (32 in.) triple semi-grouser shoes; and a 380G LC unit with 7629-kg (16,819 lb.) counterweight and 800-mm (32 in.) heavy-duty triple semi-grouser shoes.

